

B.Y.O.C. MK2 Kit Instructions

Parts Checklist.....	page 2
Populating the Circuit Board.....	page 3 - 5
Assembly.....	page 6
Wiring.....	page 7
Installing the LED and Mounting the PCB.....	page 8 - 9
Finish up.....	page 10 - 11
Schematic.....	page 12

Parts Checklist for MK2 Fuzz Kit

Resistors:

- 1 - 470ohm (yellow/purple/brown/gold)
- 1 - 1k (brown/black/red/gold)
- 1 - 4.7k (yellow/purple/red/gold)
- 1 - 10k (brown/black/orange/gold)
- 1 - 47k (yellow/purple/orange/gold)
- 3 - 100k (brown/black/yellow/gold)
- 1 - 4.7m (yellow/purple/green/gold)

Capacitors:

- 2 - .01uf film (103)
- 1 - .047uf film (473)
- 1 - 0.1uf film (104)
- 2 - 4.7uf aluminum electrolytic
- 1 - 47uf aluminum electrolytic

Transistors:

- 3 - OC75 PNP germanium transistors

Diodes:

- 1 - 1N4001

Potentiometers:

- 1 - 25k(254) or 20k(204) trim pot
- 1 - A100K Audio Volume pot
- 1 - B1K Linear Fuzz pot

Hardware:

- 1 - enclosure w/ 4 screws
- 1 - mk2 circuit board
- 1 - 3pdt footswitch
- 2 - knobs
- 1 - AC adaptor jack
- 1 - 1/4" stereo jack
- 1 - 1/4" mono jack
- 1 - battery snap
- 1 - red LED
- 1 - LED bezel
- 2 - nylon standoffs
- hook-up wire

IMPORTANT NOTE!!!!!!!!!!!!!!!!!!!!!!!!!!!!!!

This pedal has a positive ground just like the original. You do NOT need any sort of special AC power adaptor. You can still use any typical negative tip adaptor. But you CANNOT use this pedal in a daisy chain or multi-outlet adaptor with other pedals. It will work by itself, but not with other negative ground pedals. If you want to use AC power, you'll need a separate adaptor for this pedal or you can just use a battery. This pedal has very low current draw and a battery will last a long time if you unplug the input jack when not in use.

Populating the Circuit Board

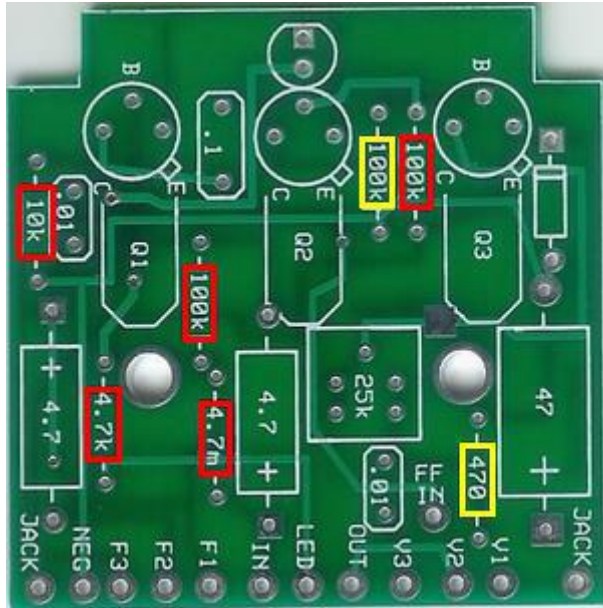

Step 1: Add all the resistors. The 4.7M is optional. It was not part of the original circuit. It is a pull down resistor to reduce any true bypass pop that may occur. You can use the 1k resistor in place of the 470ohm for more volume output. The 100k resistor highlighted in yellow is a value that is under debate. In some productions runs, it was 47k. This gives a spittier more aggressive sounding fuzz, but is a bit noisy. The 100k gives a smoother sounding fuzz and is less noisy.

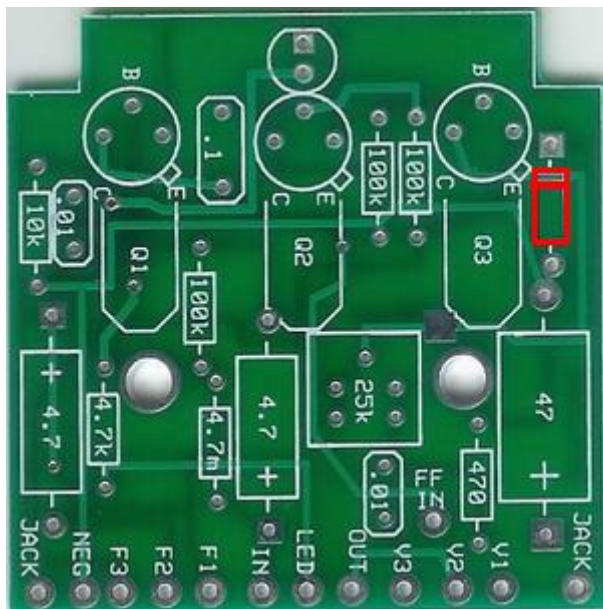

Step 2: Add diode. Make sure the stripe is facing the same direction as on the layout.

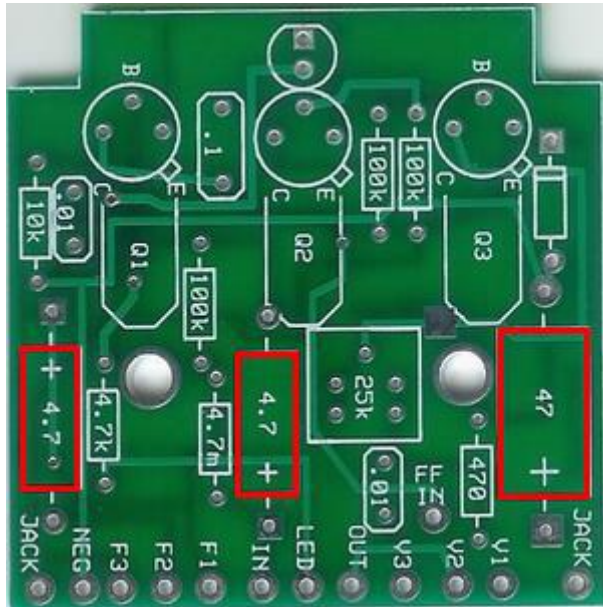

Step 5: Add the aluminum electrolytic capacitors. These are polarized and the positive solder pad will be labeled on the board by a "+" symbol. The negative end of the capacitor will have a strip of black arrows pointing to it. The positive end will have a rubber seal on that end.

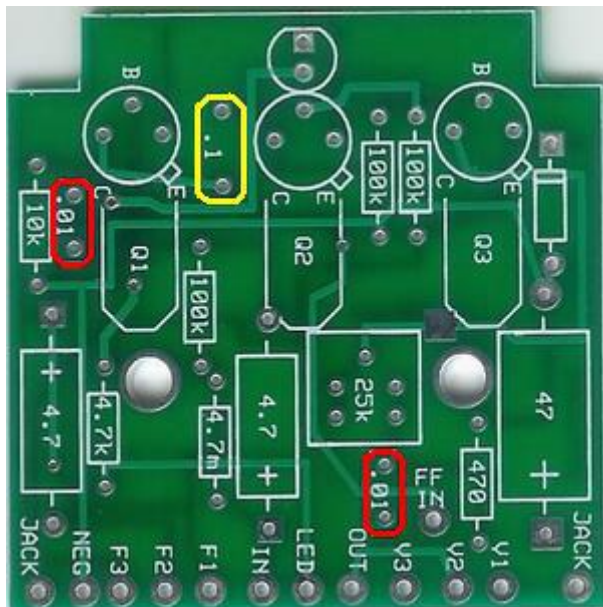

Step 6: Add the film caps. These are not polarized and can go in either direction. The .1µF cap highlighted in yellow can be replaced with the .047µF. It will reduce the woofiness of the fuzz without losing too much low end. It will also open up the tone and greatly reduce compression. This mod is highly recommended.

Assembly

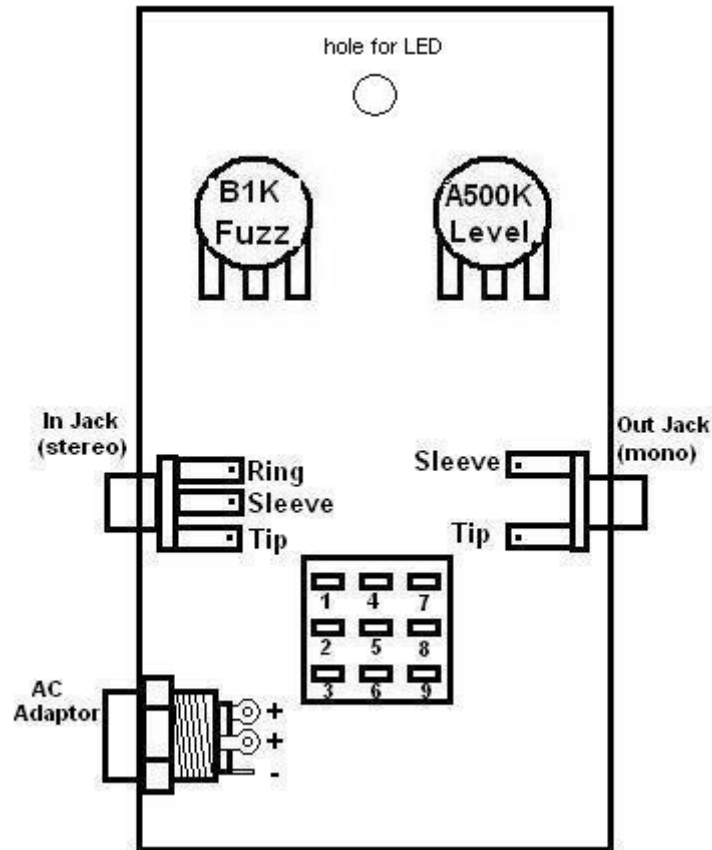

1. Install the jacks first. If you are looking down inside the enclosure, the mono jack goes on the right side and the stereo jack goes on the left. Place the washer on the outside of the enclosure. Use a 1/2" wrench to tighten.
2. Install the AC adaptor jack. The bolt goes on the inside. Use a 3/4" or 14mm wrench to tighten.
4. Install the potentiometers so that the solder lugs are pointing down. The 1k (fuzz/attack) pot goes on the left side and the 500k (volume) pot goes on the right. The washers go on the outside. Use a 10mm wrench to tighten but only snug. Do not over tighten the pots.
4. Install the footswitch. The first bolt and metal washer go inside. The plastic washer and second bolt go on the outside. It does not matter which side you designate as the "leading edge" of the footswitch as long as you orientate it so that the flat sides of the solder lugs are aligned in horizontal rows, not vertical columns.

Wiring

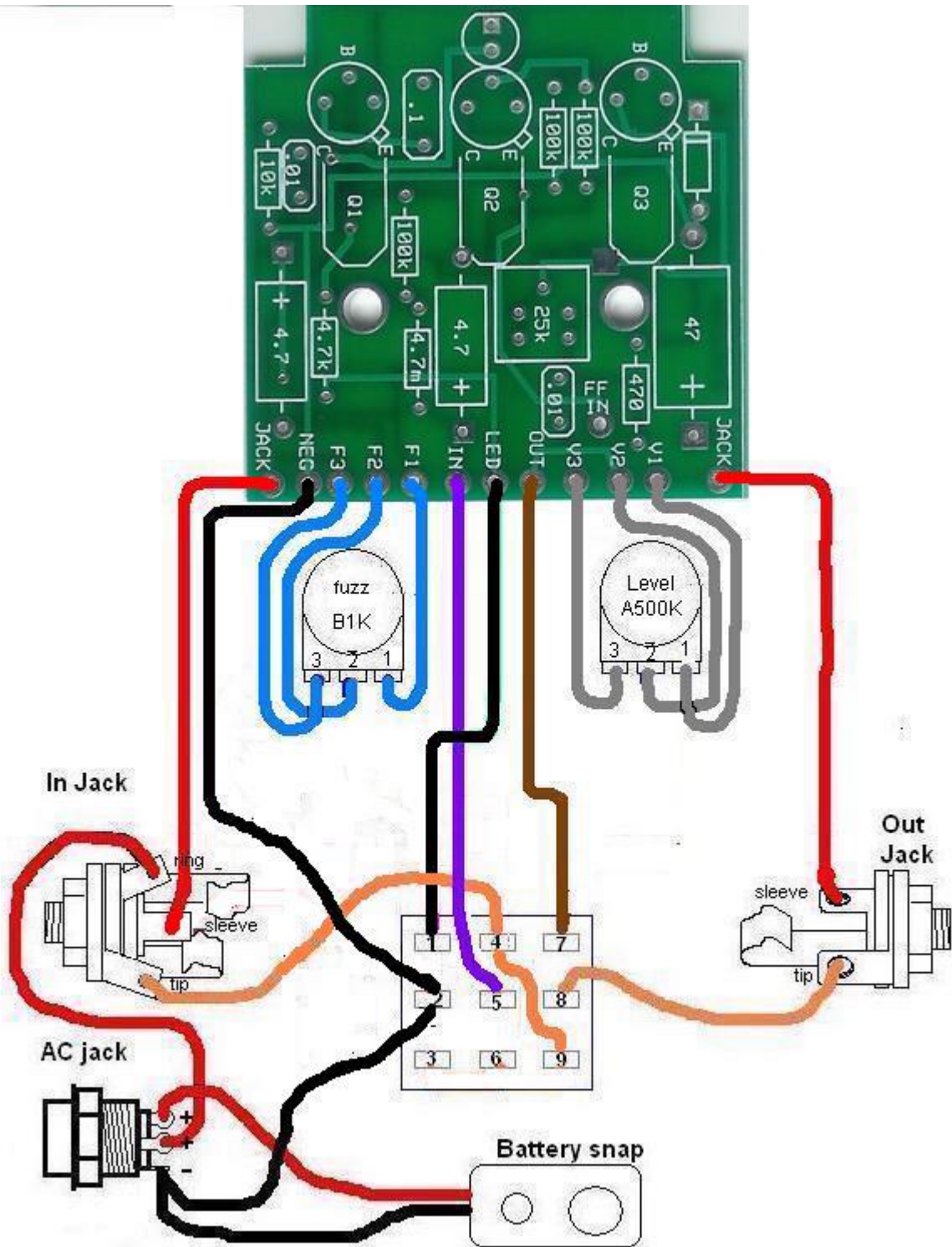

Installing the LED and Mounting the Circuit Board

1. Insert the LED into its slot on the underside or solder side of the circuit board, but DO NOT SOLDER it yet. Make sure the anode (the long leg) goes in the square solder pad and the cathode (the short leg) goes in the round solder pad. This is opposite of how a PCB mounted LED should be installed. This is unique only to the Tonebender kit.

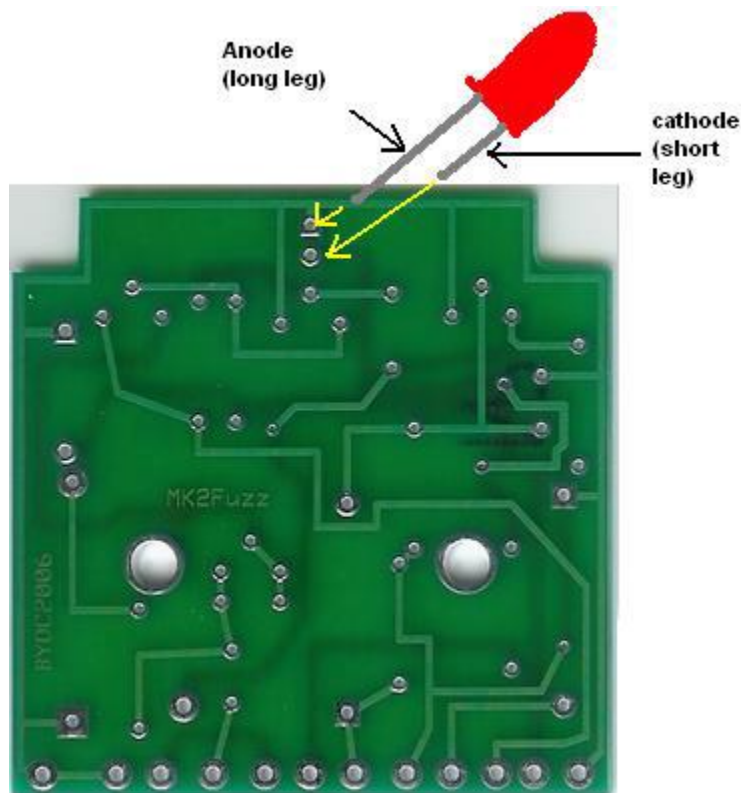

2. Once you have the LED in place, bend the leads a little bit so that it will not fall out when you turn the PCB over.
3. Install the nylon circuit board standoffs into the mounting holes.
4. Remove the paper backings on the standoff to expose the self-adhesive tape.

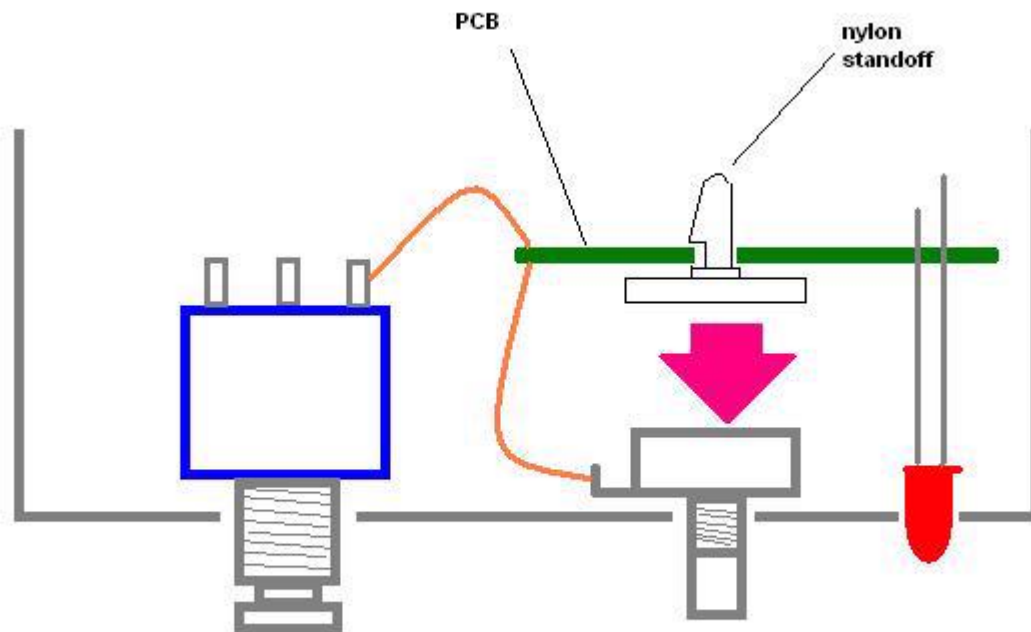

5. Insert the LED bulb into the LED hole in the enclosure.
6. Secure the Standoffs to the back of the potentiometers.
7. Your LED should still be free to move up and down slightly. You probably do not want your LED sticking all the way out of the hole. So pull up on the LED legs till you have it properly positioned and then solder.
8. Clip off the excess LED leg wire.

Finishing Touches

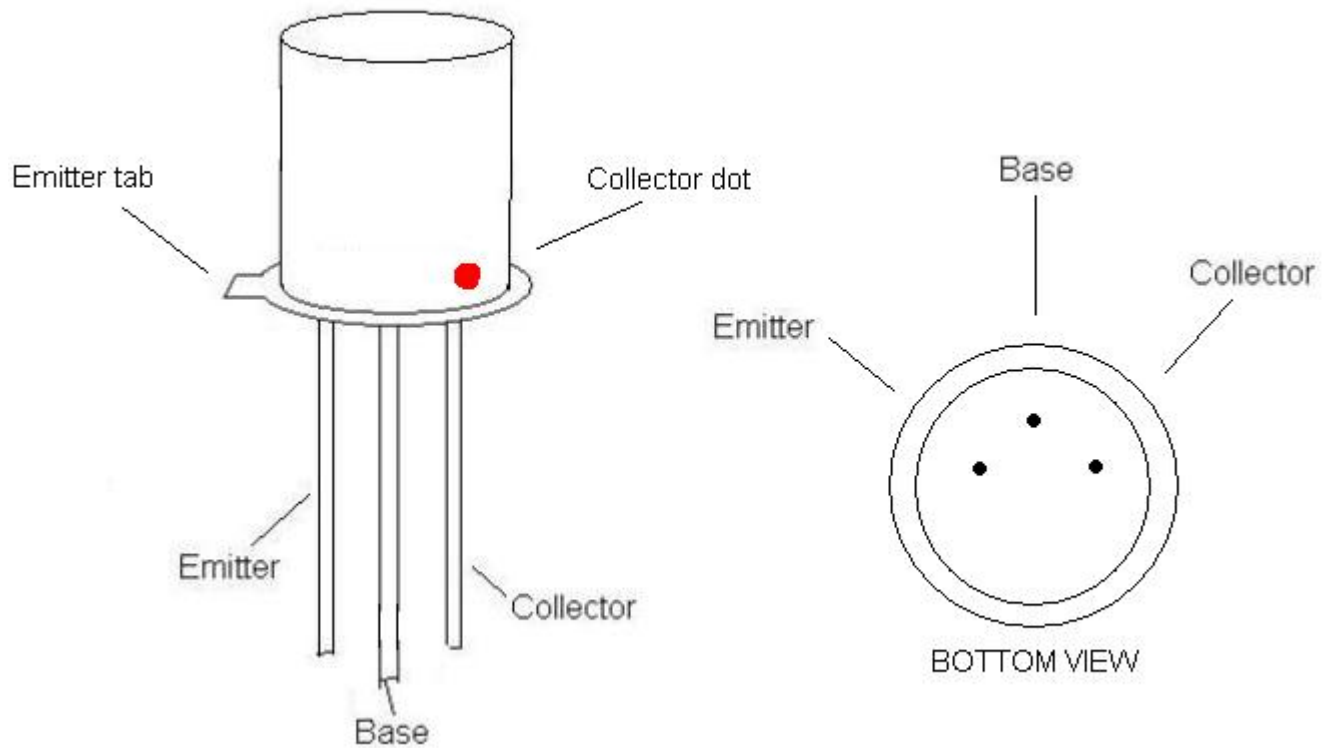

Install the transistors. Do not solder the transistors. Simply push the lead wires into the appropriate socket holes. The lead wires on the germanium transistors will be rather long, so you will want to clip off the excess. But be sure to leave enough so you can bend the transistor down and out of the way when you seal the enclosure. Some brands will only have a dot (could be any color) to denote the collector. Some brands will have a tab to denote the emitter. Some brands could have both indicators. Some brands may have neither. In this case they will positions the lead wires in a triangular formation that is offset from the center (see bottom view).

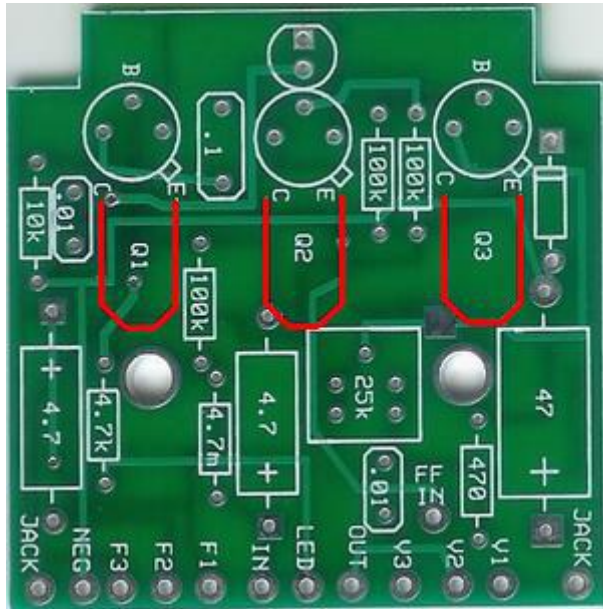

The collector goes on the left and the emitter on the right. The base is in the center. Bend the transistors down out of the way so that they lay in the space provided on the circuit board.

Once you've plugged your tonebender in and it “works”, you will probably need to bias it. Just turn the trimpot until it sounds the way you think a fuzz should sound. Most people believe the optimal bias voltage to be approx. 4.5v - 5v on the collector of Q3. There is a small probe pad provided on the PCB right next to Q3.

Install the base of the enclosure with the 4 screws that came with your kit. Add the rubber bumper feet...unless you're a velcro person. If you've got any problems that you can't figure out yourself, visit board.buildyourownclone.com for technical support

Schematic

B.J.O.C. MK2 FIZZ

