

BYOC E.S.V. 2-knob Bender Kit Instructions

Parts Checklist.....	page 2
Populating the Circuit Board.....	page 3 - 5
Assembly.....	page 6
Mounting the PCB.....	page 7 - 9
Wiring.....	page 10
Finish up.....	page 11-12
Troubleshooting Guide/Schematic.....	page 13 - 19

**THIS PEDAL HAS A POSITIVE GROUND! YOU DO NOT
NEED TO USE A SPECIAL POWER SUPPLY WITH
REVERSE POLARITY. BUT YOU CANNOT USE THIS
PEDAL ON A DAISY CHAIN WITH OTHER
NEGATIVELY GROUNDED PEDALS.**

Copyright 2008 Build Your Own Clone

Parts Checklist for BYOC ESV 2-Knob Bender Kit

Resistors:

- 1 - 470ohm (yellow/purple/brown/gold)
- 1 - 4.7k (yellow/purple/red/gold)
- 1 - 10k (brown/black/orange/gold)
- 1 - 47k (yellow/purple/orange/gold)
- 2 - 100k (brown/black/yellow/gold)
- 1 - 1M (brown/black/green/brown)

Capacitors:

- 2 - .01uf film
- 1 - .1uf film
- 2 - 4.7uf aluminum electrolytic
- 1 - 47uf aluminum electrolytic

Diodes:

- 1 - 1N4001

Transistors:

- 3 - OC75 germanium transistors
- 3 - transistor sockets

Potentiometers: Be sure to snap off the small tab on the side of each pot.

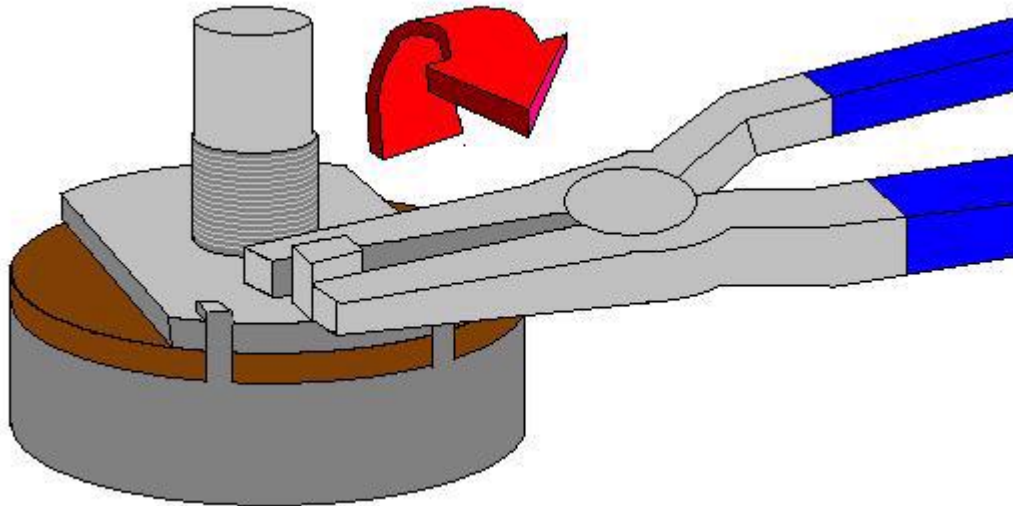

- 1 - A100k log (level)

- 1 - B1k linear (attack)

Hardware:

- 1 - drilled enclosure w/ 4 screws
- 1 - byoc 2-knob bender kit circuit board
- 1 - 3pdt footswitch
- 2 - standoffs (only in kits with solder lugged pots)
- 2 - knobs
- 1 - AC adaptor jack
- 1 - 1/4" stereo jack
- 1 - 1/4" mono jack
- 1 - battery snap
- 1 - red LED
- hook-up wire

Populating the Circuit Board

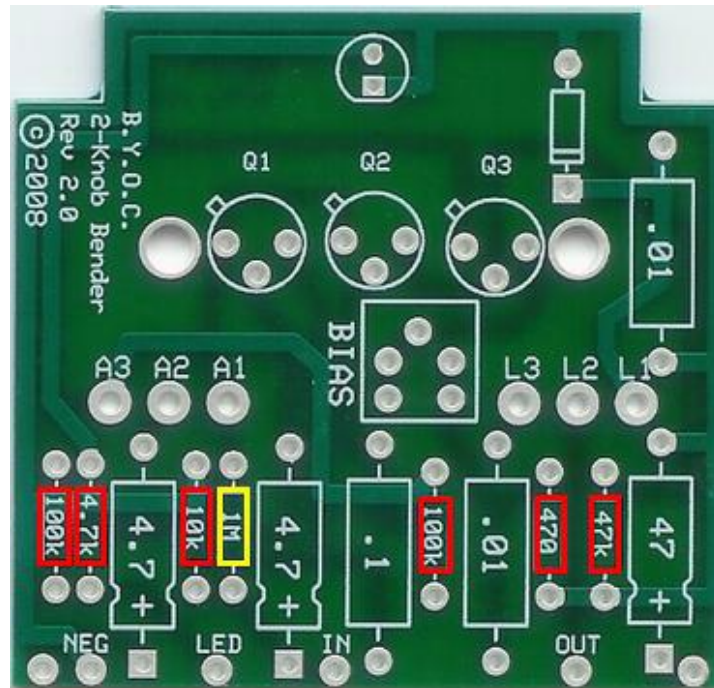

Step1: Add the resistors. Resistors are not polarized so they can go in the PCB in either direction. The 1M resistor highlighted in yellow is added for footswitch pop reduction. Omit this component if you want to keep the pedal as original as possible. It has little to no sonic affect on the circuit.

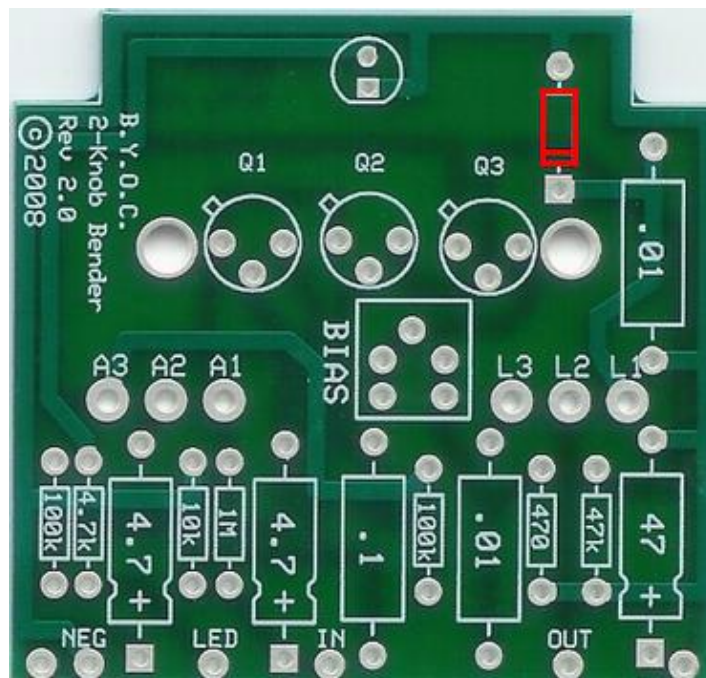

Step 2: Add the larger black plastic diode with silver stripe(1N4001). Make sure the stripe matches up with the layout on the PCB. The cathode(striped end) goes in the square solder pad. The anode goes in the round solder pad. This component was not part of the original circuit. It has been added for accidental reverse polarity protection. Omit it if you want to keep the circuit as original as possible. It has no sonic affect on the circuit.

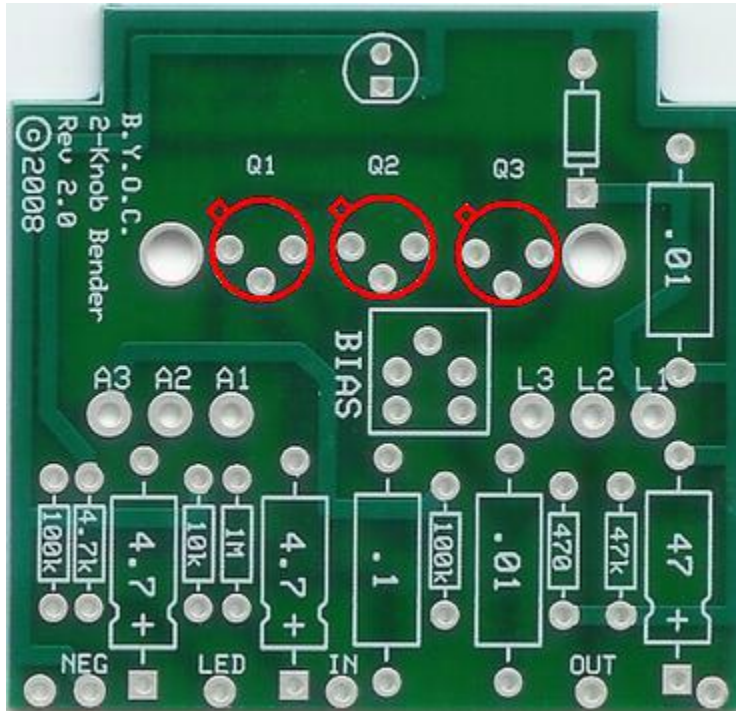

Step 3: Add the transistor sockets. **DO NOT SOLDER THE TRANSISTORS TO THE SOCKETS!!!!!!!!!!!!** Only solder the sockets to the PCB. Make sure to match the tab of the socket to the tab of the PCB layout.

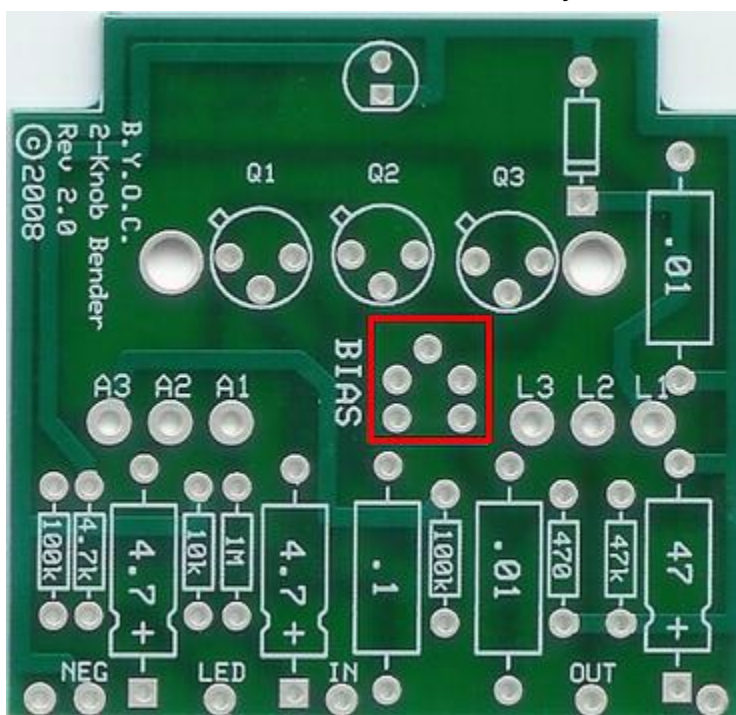

Step 4: Add the bias trimpot. Do not be confused by the fact that the PCB has holes for 5 legs and the actual trimpot only has 3. This is so that the PCB can accept a variety of trimpots. There should be only one way in which your trimpot will fit the PCB without having to bend any of the legs.

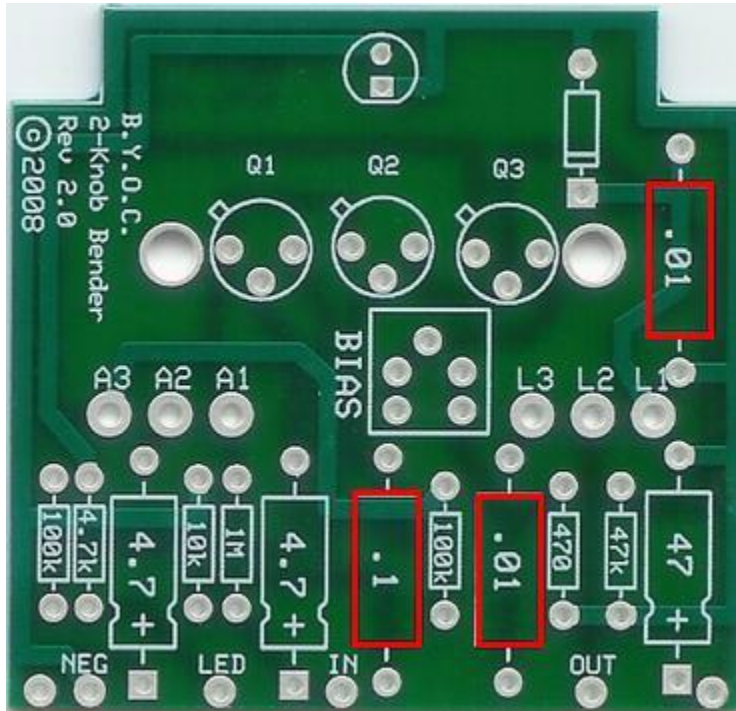

Step 5: Add the yellow radial led metal film capacitors. These are not polarized and can go in the PCB in either direction.

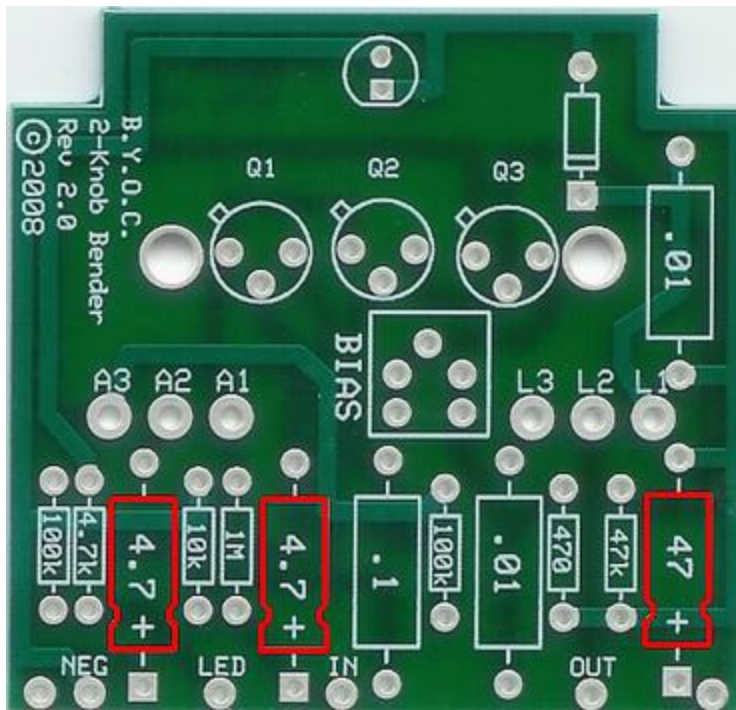

Step6: Add the aluminum electrolytic capacitors. These are polarize. The positive end goes in the square solder pad. The positive end will have an indented ring around one end

Assembly

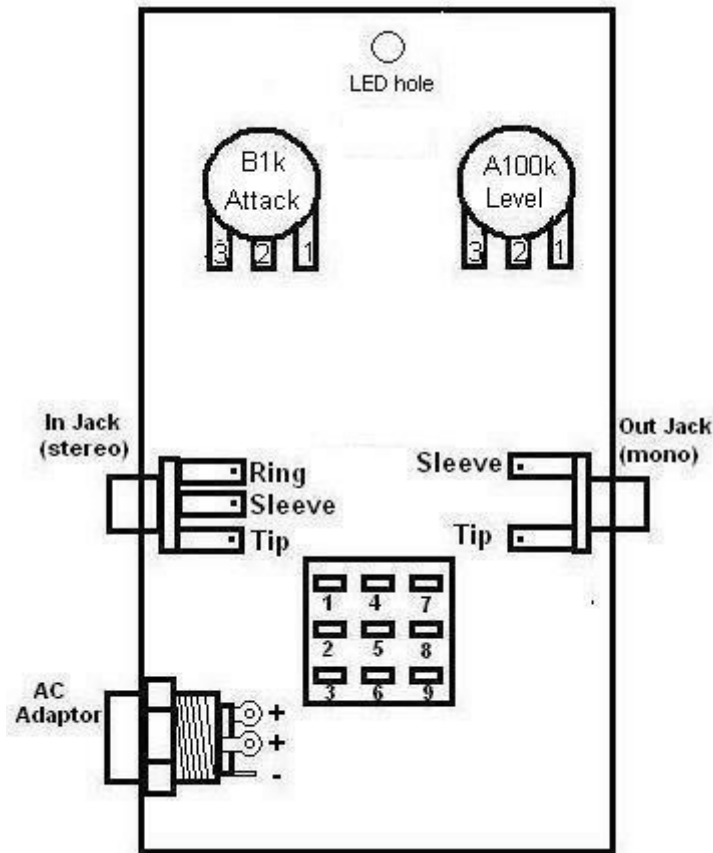

1. Install the jacks first. If you are looking down inside the enclosure, the mono jack goes on the right side and the stereo jack goes on the left. Place the washer on the outside of the enclosure. Use a 1/2" wrench to tighten
2. Install the AC adaptor jack. The bolt goes on the inside. Use a 3/4" or 14mm wrench to tighten
3. Install the potentiometers so that the solder lugs are pointing down. The washers go on the outside. Use a 10mm wrench to tighten but only snug. Do not over tighten the pots. You should leave the pots somewhat loose until they are soldered to the PCB so that it will be easier to mount them.
4. Install the footswitch. The first bolt and metal washer go inside. The plastic washer and second bolt go on the outside. It does not matter which side you designate as the "leading edge" of the footswitch as long as you orient it so that the flat sides of the solder lugs are aligned in horizontal rows, not vertical columns.

Mounting the Circuit Board

PC Mounted Potentiometers: Some kits will come with PC mounted pots depending upon availability. If your kit has PC mounted pots follow these steps for mounting the circuit board.

Step1: Understand that the LED, and both potentiometers will be mounted and soldered directly to the underside of the PCB. You should do the actual soldering on the topsid of the PCB. Read through all the steps in this portion before doing anything so that you can get the “big picture”.

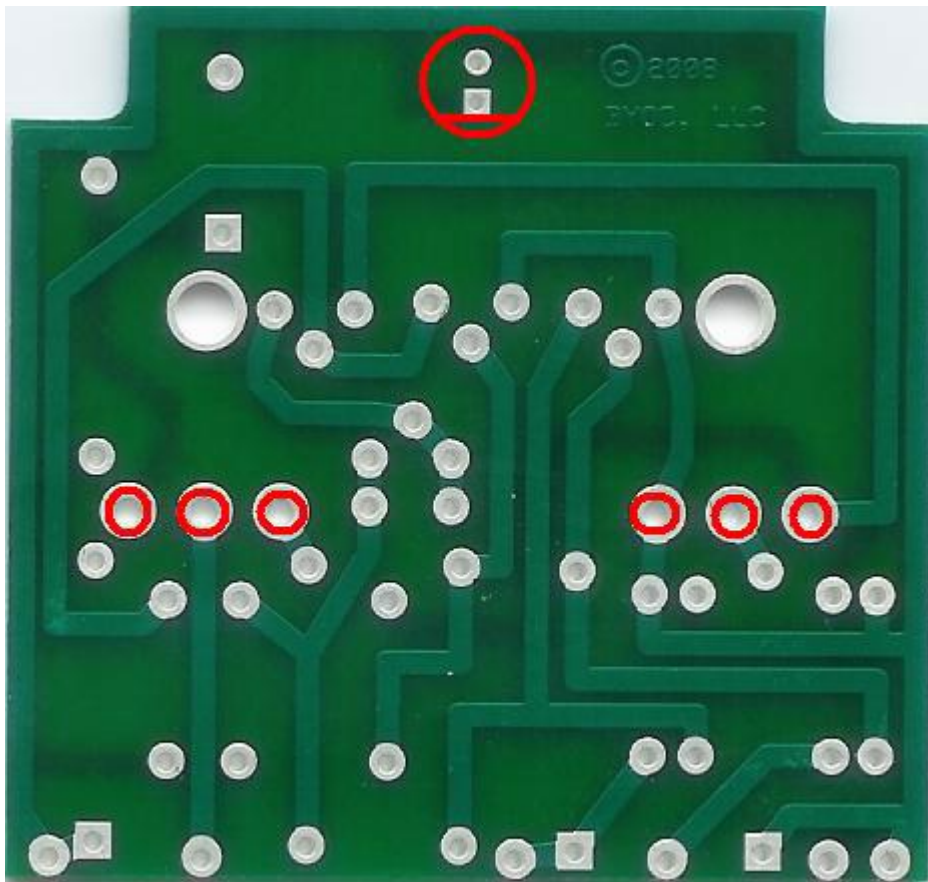

Step 2: Install the LED but do not solder it or clip the leads. You will insert the LED into its eyelets. Make sure the longer lead goes in the round eyelet and the shorter lead goes in the square eyelet. Yes this is correct! Longer lead in the round eyelet. Shorter lead in the square eyelet. Now bend the leads of the LED so that it will not fall out of the PCB when you flip it over.

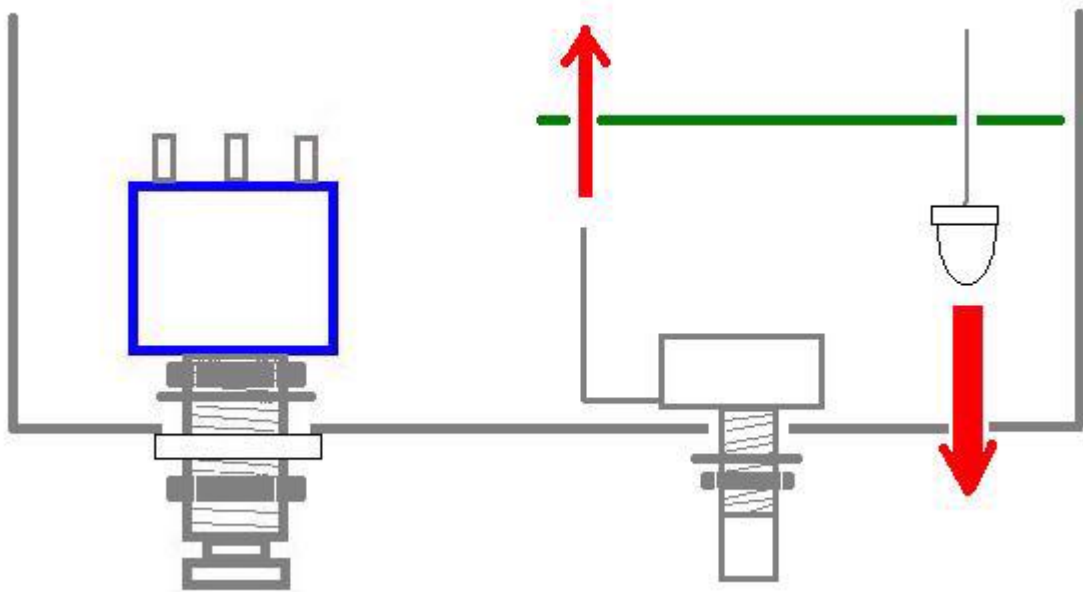

Step 3: Now mount the PCB with LED onto the leads of the potentiometers. This move may take a little finesse. It's best to leave your pots somewhat loosely mounted to the enclosure so that you can easily move them to line up with the eyelets on the PCB. You may need to bend the leads of the pots into place if they were bent in shipping.

Step 4: once you have the PCB in place, snug the nuts of the pots and toggle switch with your fingers.

Step 5: Move the LED into place by guiding it with the leads that are sticking out of the top side of the PCB.

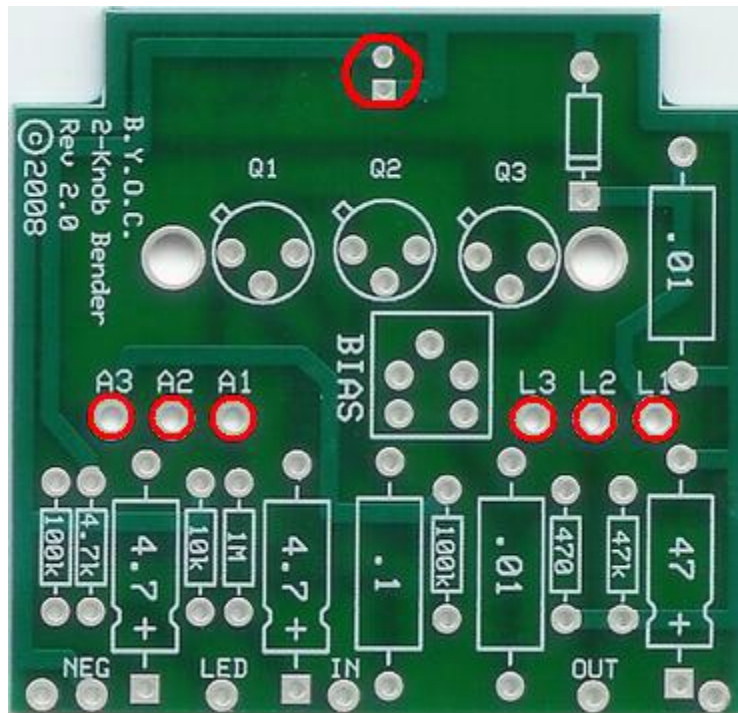

Step 6: Solder the LED and pots on the top side of the PCB. Clip the excess LED leads.

Do not clip the leads of the pots.

Solder Lugged Pots: Some kits may come with panel mounted pots with solder lug termination. If you kit has these style pots, follow these steps for mounting the PCB.

Step 1: Connect the pots to their eyelets on the PCB with hook up wire. Insert the wires from the underside of the PCB and solder on the topside. Lug 1 of the A100k LEVEL pot goes to the L1 eyelet. Lug 2 of the LEVEL pot goes to the L2 eyelet. Lug 3 of the LEVEL pot goes to the L3 eyelet. Lug 1 of the B1k ATTACK pot goes to the A1 eyelet. Lug 2 of the ATTACK pot goes to the A2 eyelet. Lug 3 of the ATTACK pot goes to the A3 eyelet.

Step 2: Install the self-adhesive nylon standoffs from the underside of the PCB into the large mounting eyelets, but do not remove the paper backings yet.

Step 3: Install the LED into the underside of the PCB, but **DO NOT SOLDER IT YET!** The longer lead goes in the round pad and the shorter lead goes in the square pad. Not that's not a typo. Yes that is correct. Longer lead in the round pad. Shorter lead in the square pad. Bend the leads of the LED outward on the topside of the PCB so that it does not fall out when you flip it over.

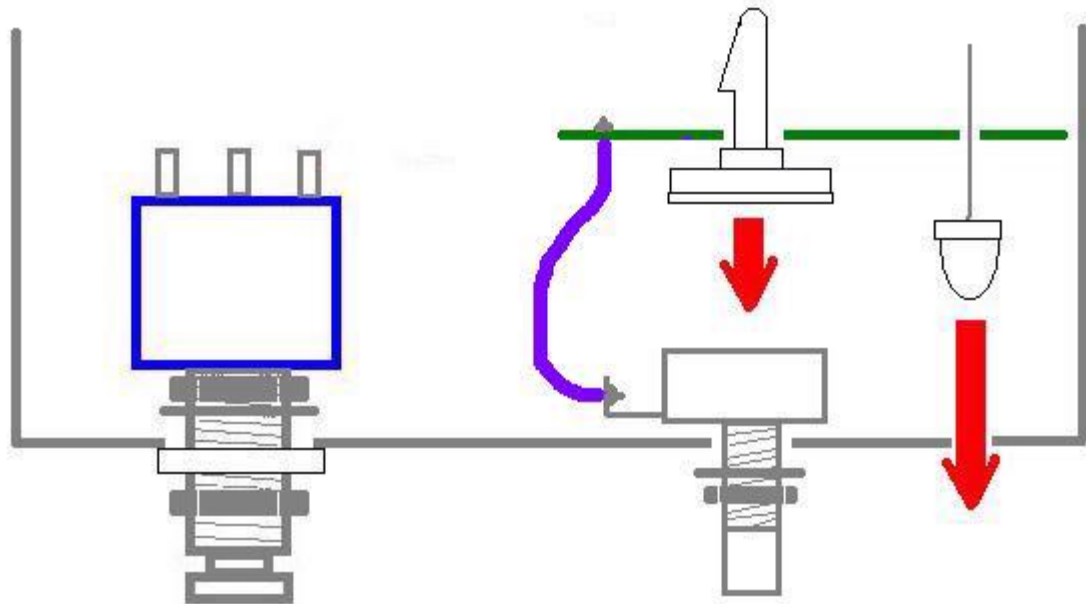

Step 4: Now remove the paper backings from the standoffs and adhere them to the backs of the pots. It's a good idea to clean the backs of your pots with some rubbing alcohol first.

Step 5: Grab the LED by the leads that are sticking out of the topside of the PCB and guide it into place. Solder it from the topside and clip the excess leads.

WIRING

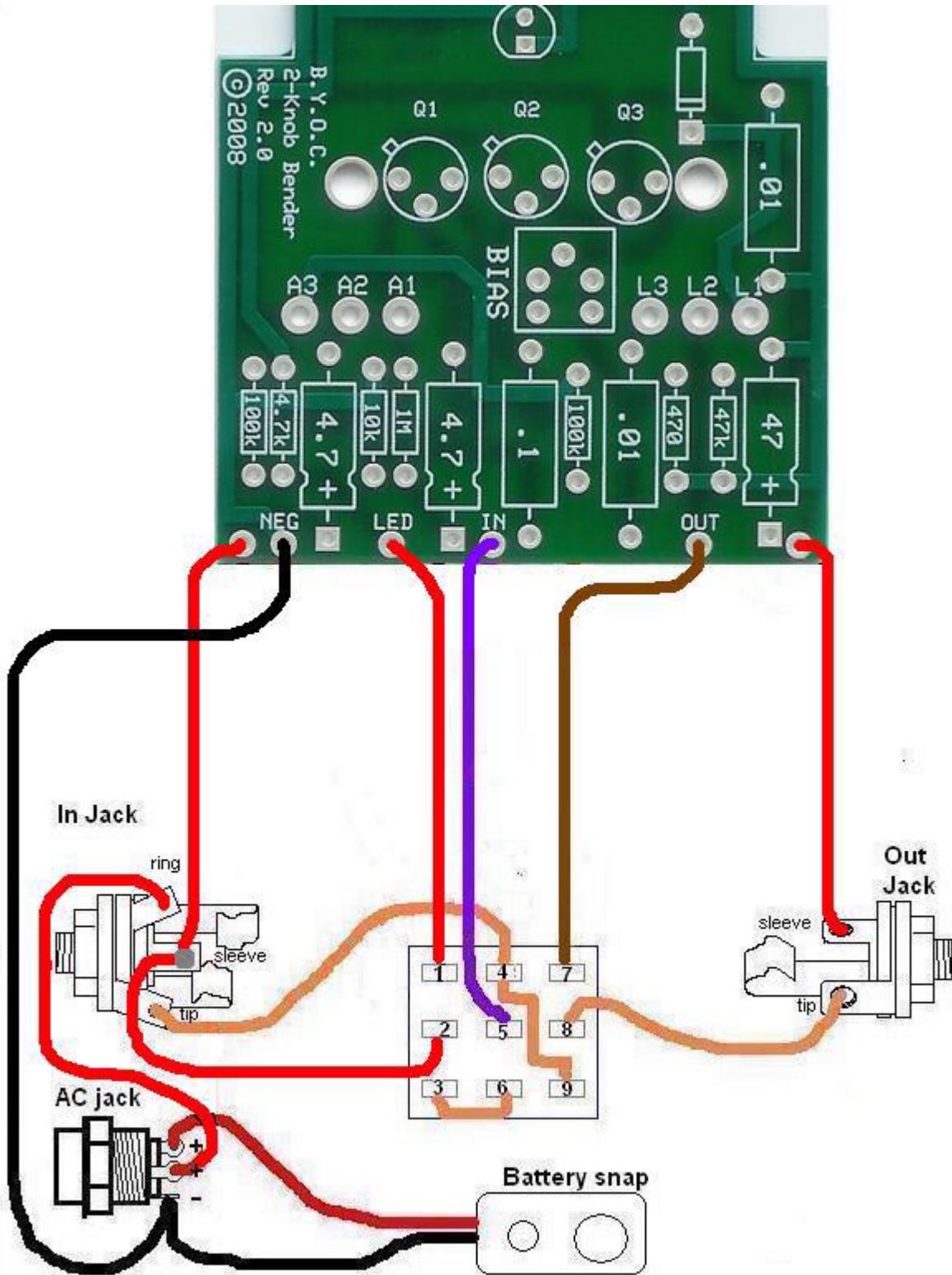

Finishing Touches

Orienting the OC75

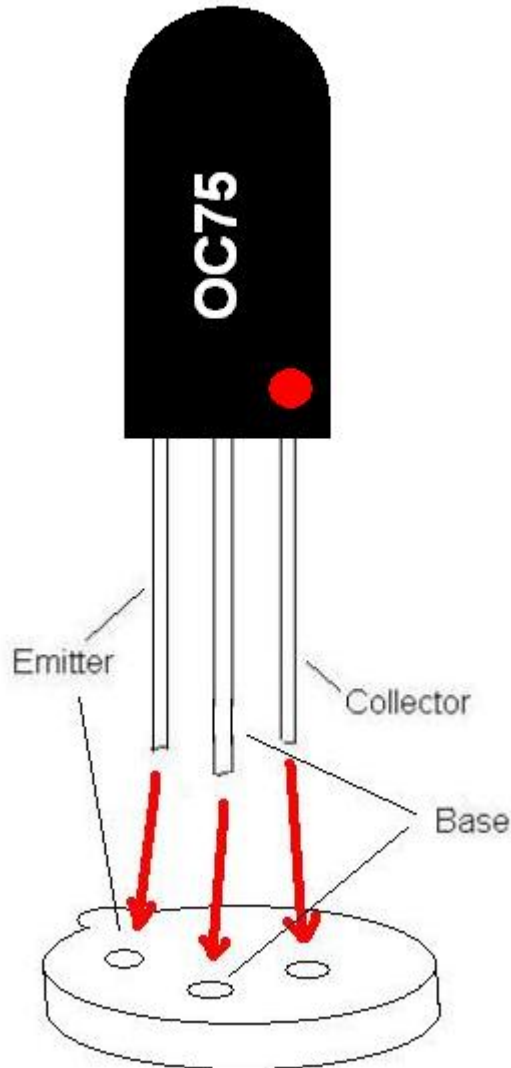

Add the OC75 transistors to their sockets.

DO NOT SOLDER THEM!!!!!!!!!!
DO NOT CLIP THEIR LEADS!!!!!!!!!!

Soldering or clipping them will void your warranty. We will not accept returns if they are used. Install your transistors into their sockets with full leads to test the pedal first. When you know that your pedal works and sounds the way you expect it to, then clip the leads and re-install the transistors. You need to push the leads into their sockets firmly. You should use a pair of needle nose pliers. Once in their sockets, the transistors will be very

secure. If your transistors come out easily, then you have not installed them correctly and you will likely not get a good connection, and this will likely lead to a poor sounding pedal.

Once you have installed your transistors, adjust the bias trimpot to taste. You can use your ear for this. There is no "correct" bias voltage. Install the base of the enclosure with the 4 screws that came with your kit. Add the rubber bumper feet...unless you're a velcro person. Add the 2 knobs. Be sure not to tighten the set screw inside the knobs too tight or you may strip them. If you've got any problems that you can't figure out yourself, visit board.buildyourownclone.com for technical support. Please read the trouble shooting guide first.

Trouble Shooting Guide

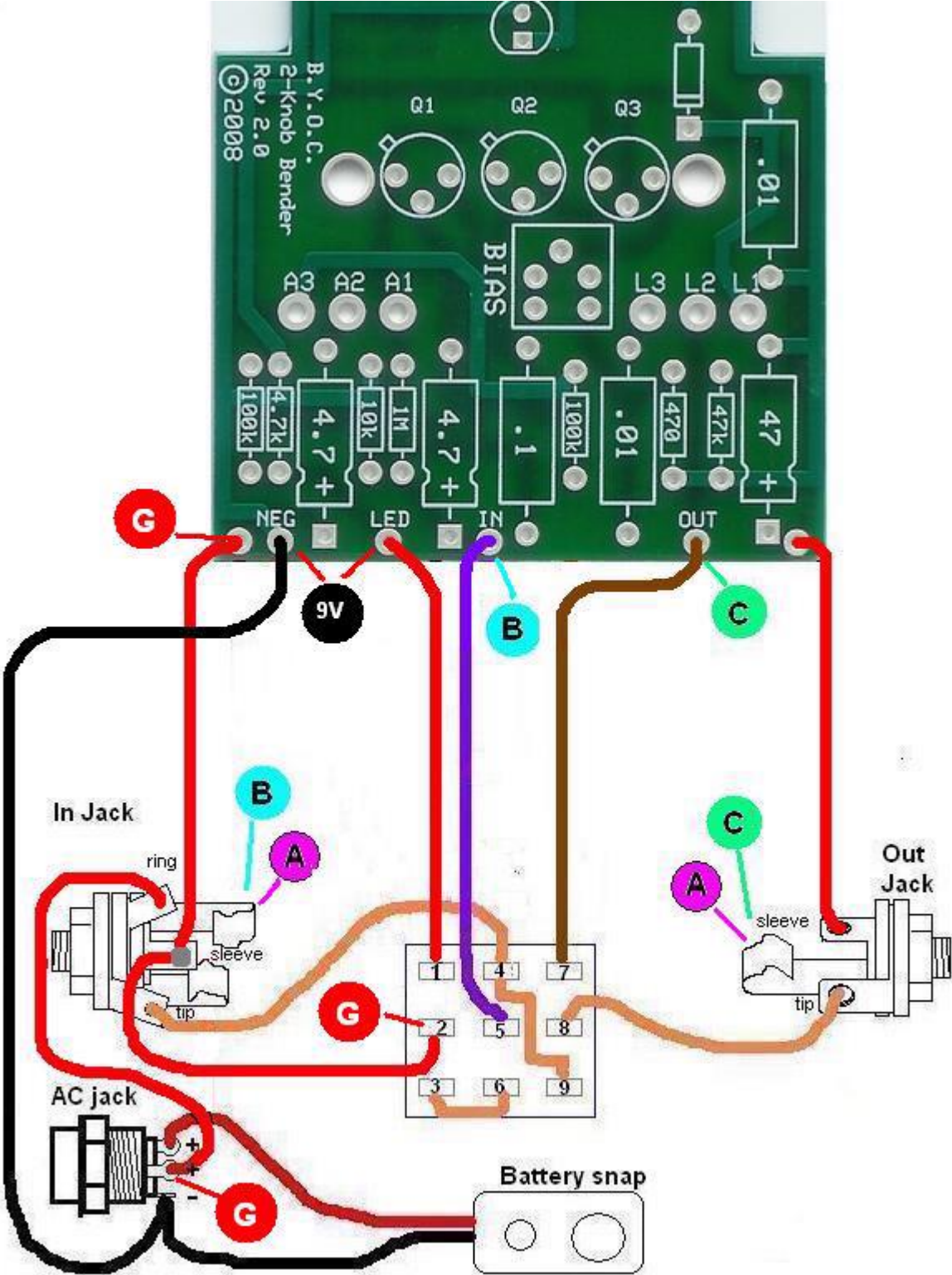

Checking your wiring

1. NO POWER: If you have a completely dead pedal and your LED will not light up, this is usually a good sign that you are not getting power to the circuit. First you need to make sure that you are using a fresh battery or good power supply. . Also make sure you have a plug in the IN jack. This acts as your power switch. Now let's make sure you have a good ground. Set your Digital MultiMeter to test for continuity. Continuity is the setting where the meter makes a noise when you touch the two probes together. Now test the "G" locations in the wiring diagram and make sure that there is continuity between all. ***If you don't get continuity between all 3 locations, you likely have a bad connection along the red wire.**

Now set your meter to test for 9VDC. Make sure you do not set it to test for AC. And if you do not have an auto-ranging meter you will need to set it for the proper voltage. You want to set it to test for the lowest voltage without going under 9V. This will probably be 20V on most meters. With the pedal/footswitch in the engaged position, you should get approximately 9VDC when you touch the black probe to the NEG eyelet and the red probe to the LED eyelet. You will probably get a little more than 9V with an adaptor and a little less than 9V with a battery.

If you are not getting a reading here, keep the black probe on the NEG eyelet and move the black probe to one of the "G" locations.

***If you do not get a reading now, you likely have a bad connection somewhere along the black wire.**

If you don't get a 9V reading at the NEG and LED eyelets, but you do get a 9V reading at the NEG eyelet and all of the "G" locations, and you are certain that your footswitch is in an engaged state, there is a possibility that you have a faulty footswitch or a bad connection at lugs 1 and/or 2 of the footswitch. Test for continuity between lugs one and two of the footswitch. Make sure to press the footswitch on and off so that you are certain that you are engaging the throw between lugs 1 and 2 one way or the other.

***If you are getting continuity between lugs 1 and 2, then you likely have a bad solder joint at lugs 1, 2, and/or the LED solder pad.**

***If you are not getting continuity between lugs 1 and 2 regardless of what state the footswitch is in, then you likely have a faulty footswitch.**

2. NO BYPASS: Set your DMM to test for continuity. Touch the probes to the "A" locations which would be the TIPS of the 1/4" jacks. When your footswitch is in the bypass state, you should have continuity between the two "A" locations. Test lugs 8 and 9 of the footswitch for continuity.

***If you get continuity between lugs 8 and 9, but no continuity between the 2 "A" locations, then you likely have a bad solder joint somewhere along the orange wiring. This also includes the jumper connection between lugs 4 and 9.**

***If you do not get continuity between lugs 8 and 9 and you are certain that the footswitch is in the bypass state, then you likely have a faulty footswitch.**

3. BYPASS WORKS, BUT THE EFFECT DOES NOT: This could be any number of problems located on the PBC, but let's check your offboard wiring first and make sure that you are getting signal to and from the PCB to rule that problem out. Set your DMM to test for continuity. Make sure your footswitch is in the "ENGAGED" state. You should get continuity between the two "B" locations and between the two "C" locations. If you do not get continuity between the "B" locations, check for continuity between lugs 4 and 5. If you do not get continuity between the "C" locations, check for continuity between lugs 7 and 8,

***If you get continuity between lugs 4 and 5, but no continuity between the "B" locations, then you likely have a bad solder joint along the purple wire.**

***If you get continuity between lugs 7 and 8, but no continuity between the "C" locations, then you likely have a bad solder joint along the brown wire.**

***If you don't get continuity between lugs 4 and 5, or lugs 7 and 8, and you are certain that your footswitch is in the engaged state, then you likely have a faulty footswitch.**

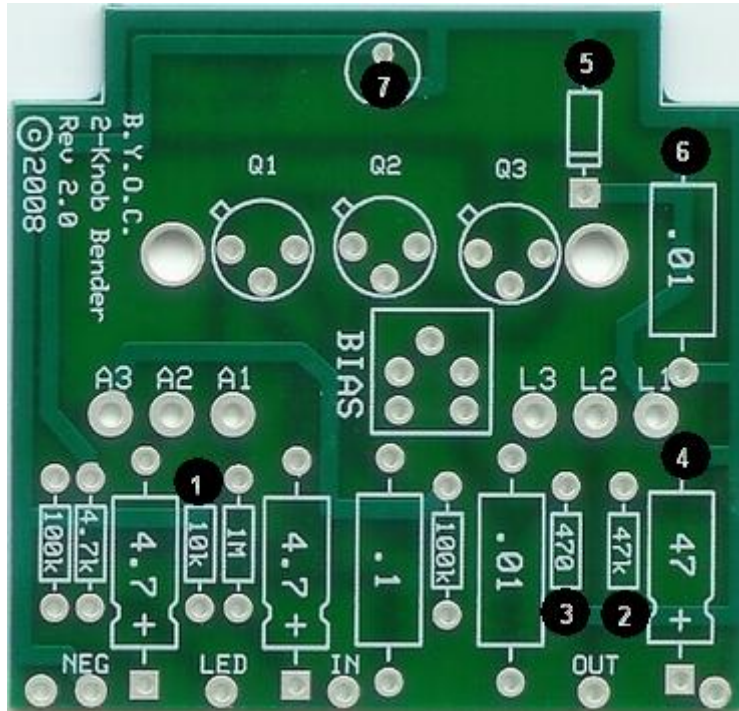

2. Check all Full Voltage connections. . Set your DMM to test for 9VDC. Touch the red probe to the sleeve of either jack. Touch the black probe to the various “black” test locations on the PCB. You should get 9V at all black locations.

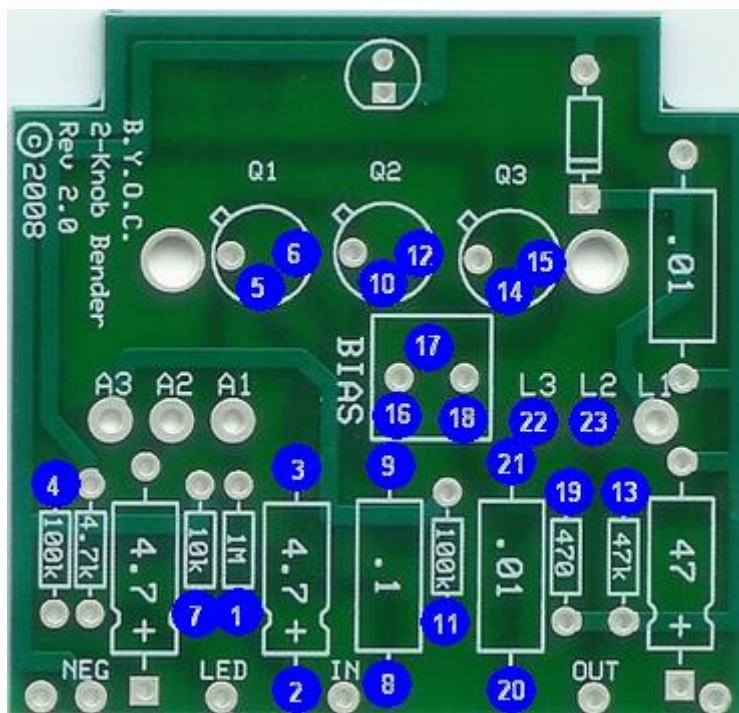

4. Test the audio signal path. Do this using a Signal Tester. A bad solder joint anywhere along here will obviously mean no sound. If you signal level drops at BLUE6, 12, or 15, you may have a dying transistor or have installed your transistor backwards. A “scratcy record” noise in the back ground is usually a good sign of a dying transistor. If you trace

out the signal path and notice the noise at BLUE6, then it is likely that Q1 is bad. If the noise begins at BLUE12 then it is likely Q2. And if it doesn't begin until BLUE16, then it is likely Q3. If you signal stops abruptly at BLUE6, 12, or 16, then the corresponding transistor is likely completely dead or there is a problem at one of the "GREEN" locations.

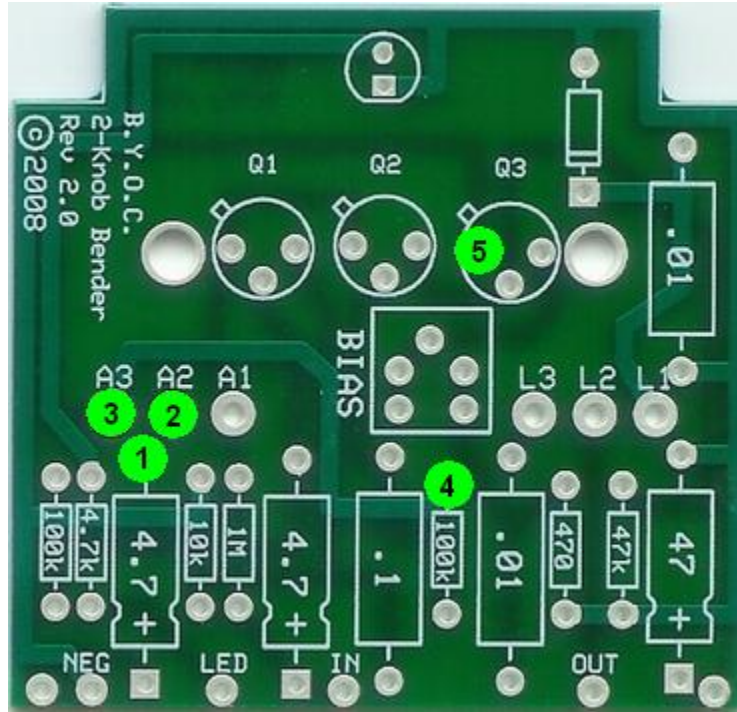

©2008 byoc, LLC

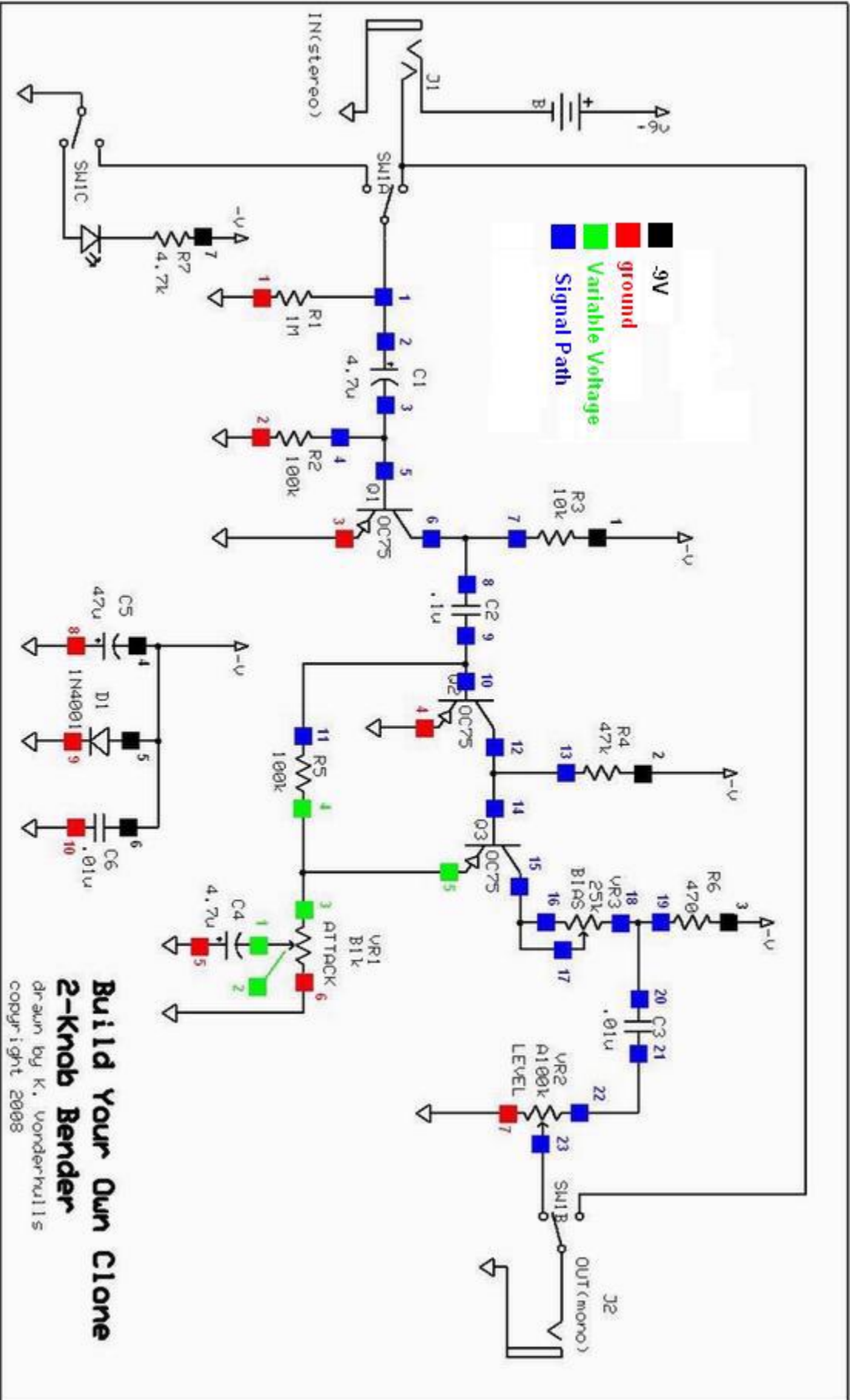

Build Your Own Clone 2-Knob Bender

drawn by K. Vanderhulst
copyright 2008